

4 3 2 1

H  
G  
F  
E  
D  
C  
B  
A

H  
G  
F  
E  
D  
C  
B  
A

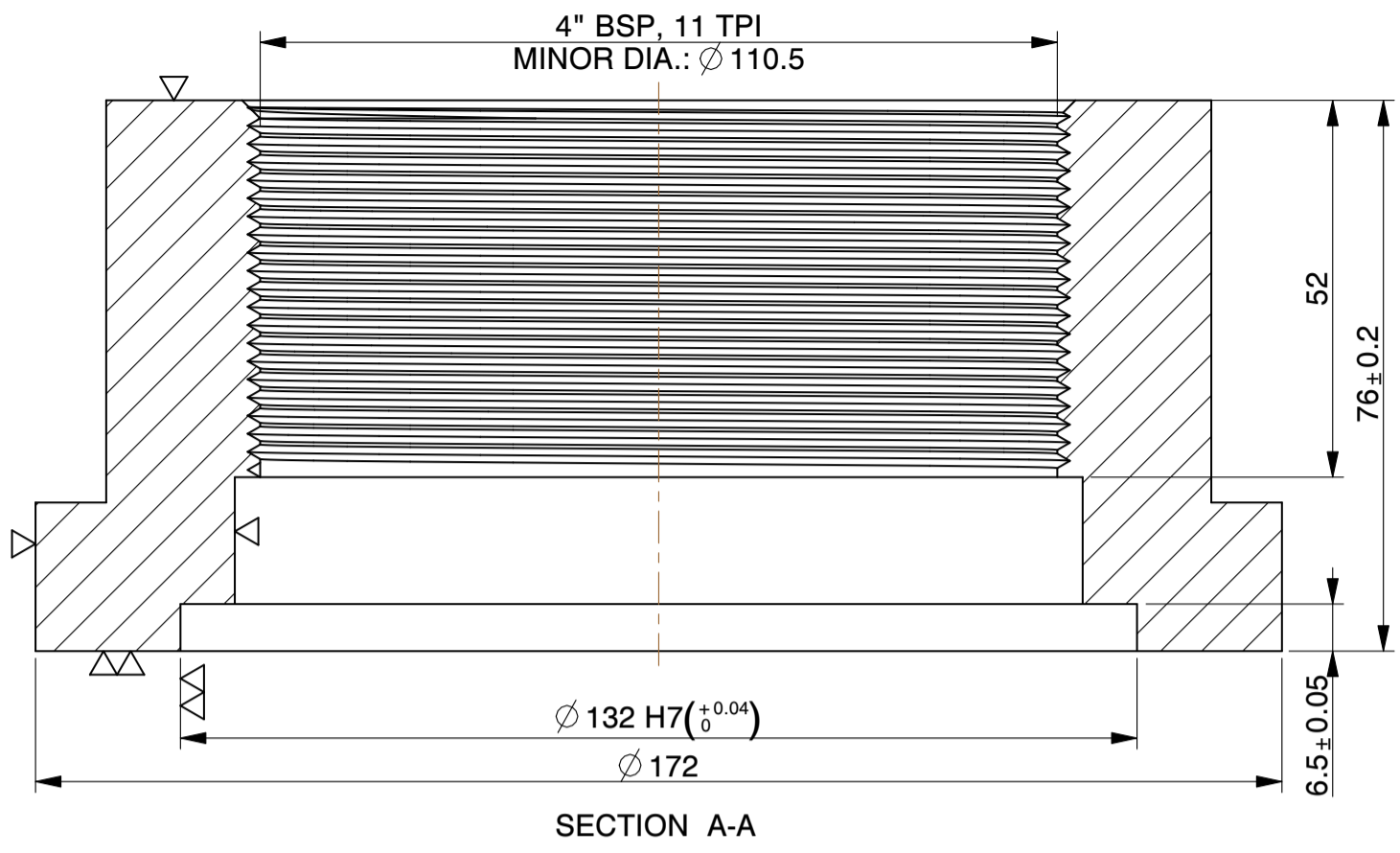

SECTION A-A

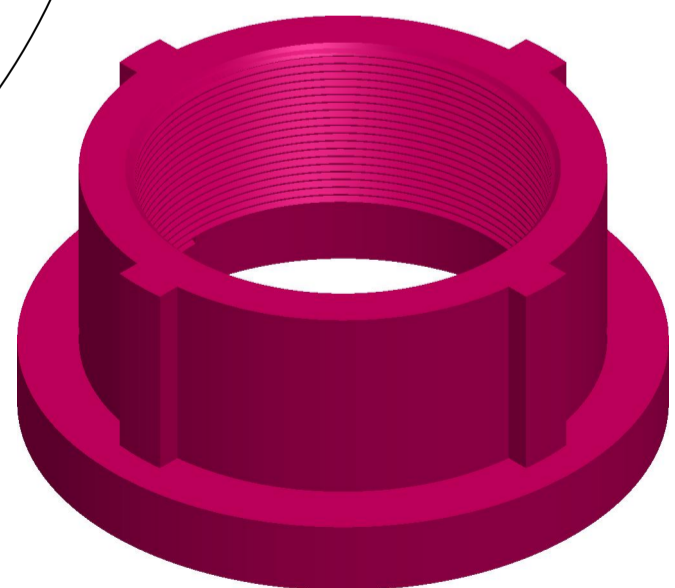
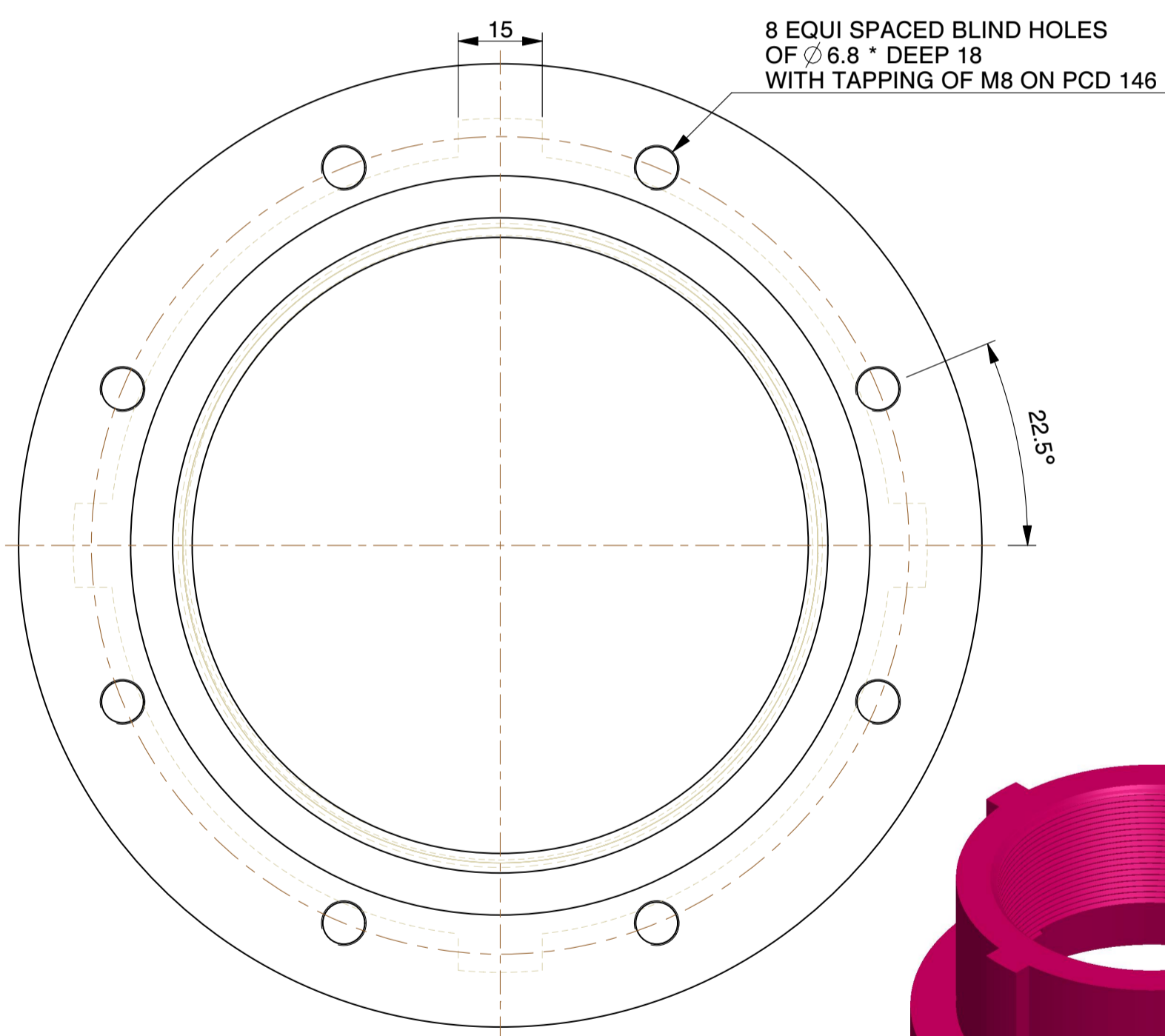

WEIGHT (AS CAST) :- 4.8 Kg.

NOTE:-  
 1).ALL DIMENSIONS ARE IN mm.  
 2).DO NOT SCALE,IF ANY DOUBT PLEASE ASK.  
 3).ALL DIMENSIONS ARE AS MACHINED.

<b>MICROCARE TECHNIQUES P. LTD.</b>		
Survey No.11,Nr. Kalpataru Society, Village : Zundal. Dist. :Gandhinagar-382421, Gujarat, INDIA. email: microcare25@microcaregroup.com		
PART NAME:	NRV - 333 - 4" SHORT	SCALE 1:1
MATERIAL: CAST IRON	DESCRIPTION: -	DATE 17-05-2011