

4 3 2 1

H

G

F

E

D

C

B

A

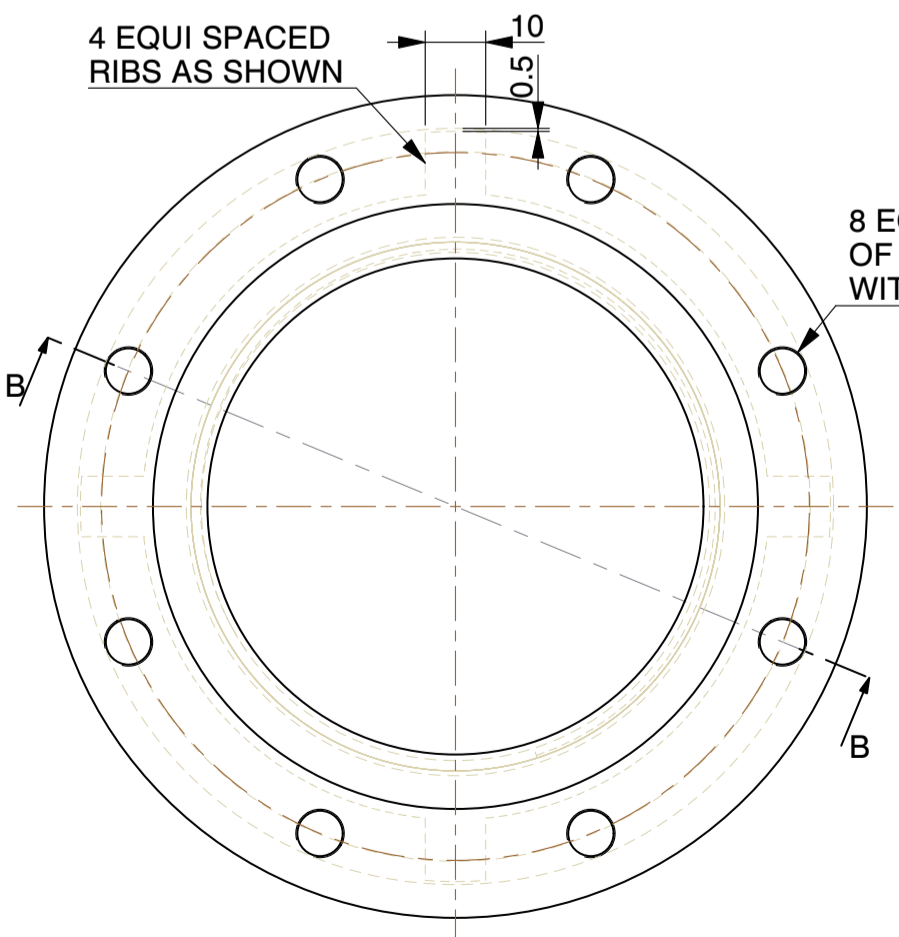
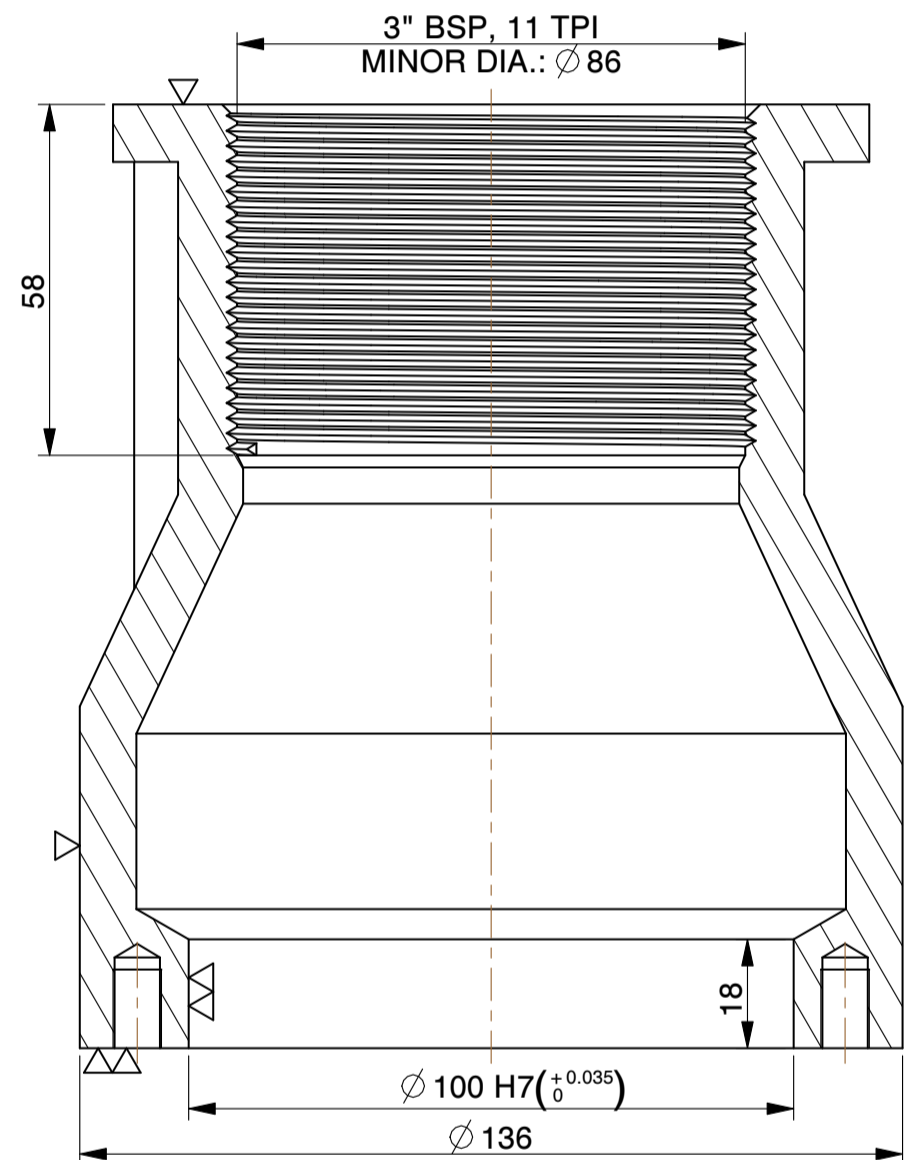
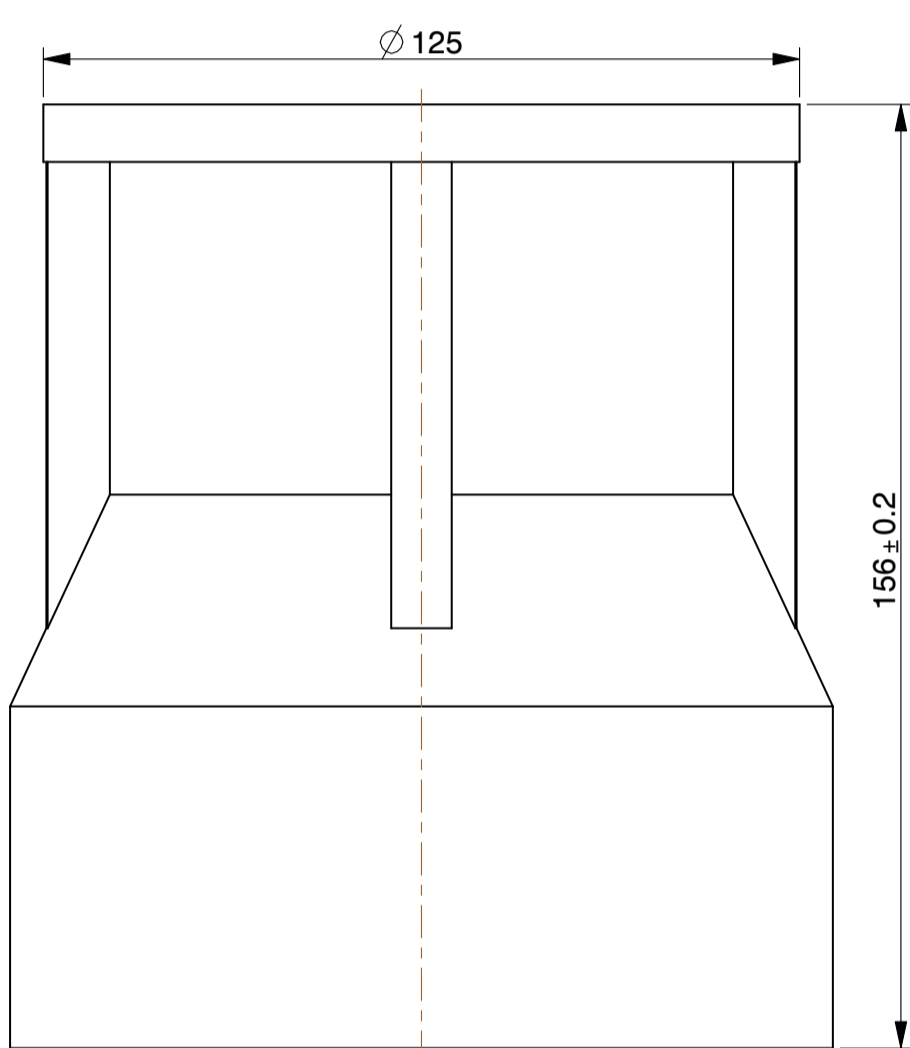
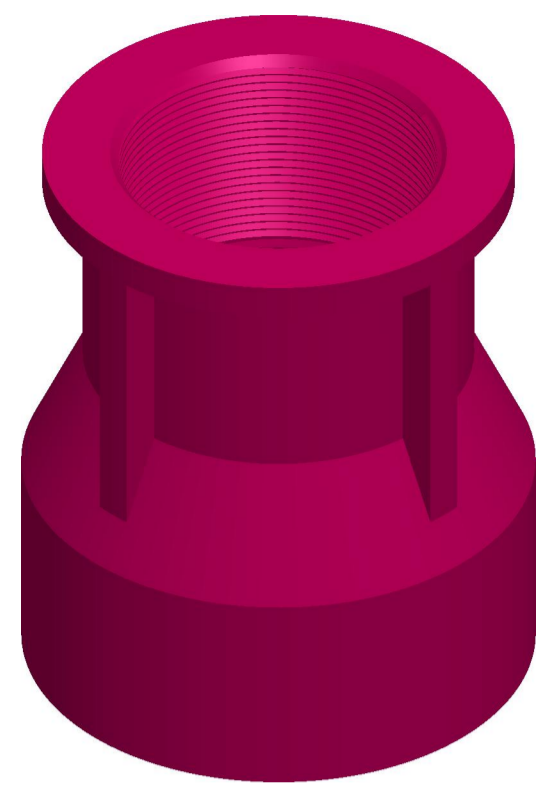

4 EQUI SPACED RIBS AS SHOWN

8 EQUI SPACED BLIND HOLES OF $\phi 6.8$ * DEEP 15 WITH TAPPING OF M8 ON PCD 117

NOTE:-
 1).ALL DIMENSIONS ARE IN mm.
 2).DO NOT SCALE,IF ANY DOUBT PLEASE ASK.
 3).ALL DIMENSIONS ARE AS MACHINED.

WEIGHT (AS CAST) :- 5.7 Kg.

MICROCARE TECHNIQUES P. LTD.		
Survey No.11,Nr. Kalpataru Society, Village : Zundal.		
Dist. :Gandhinagar-382421, Gujarat, INDIA. email: microcare25@microcaregroup.com		
PART NAME:	SCALE	
NRV COMMON FOR 242 / 273 / 302 - 3"	1:1.25	
MATERIAL:	DESCRIPTION:	DATE
CAST IRON	3" BSP THREADS WITH 11 TPI	17-05-2011

4 3 2 1