

8 EQUIDISTANCE HOLES
 ϕ 11.5 ON PCD 168

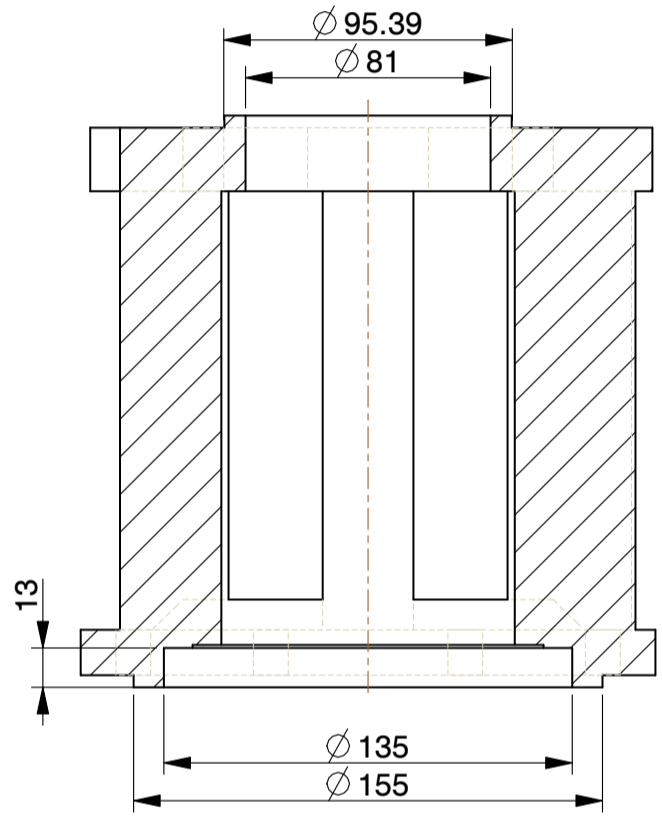

SECTION A-A

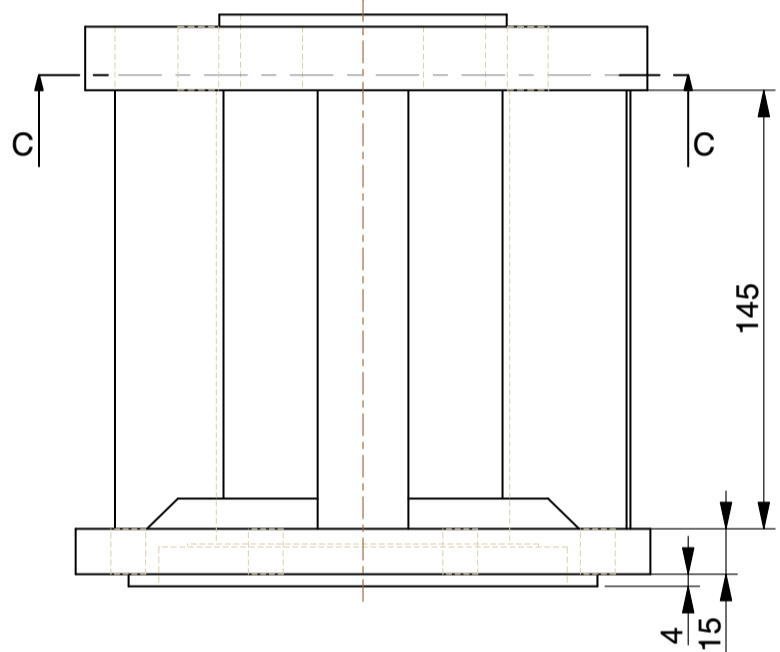
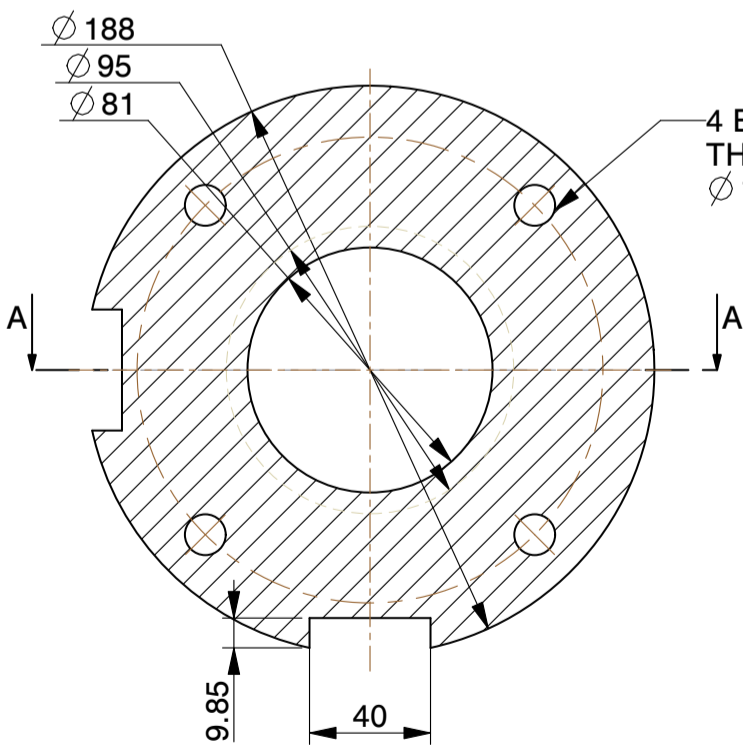

4 EQUISPACED THRU HOLES OF
 ϕ 13.5 ON PCD 154

SECTION C-C

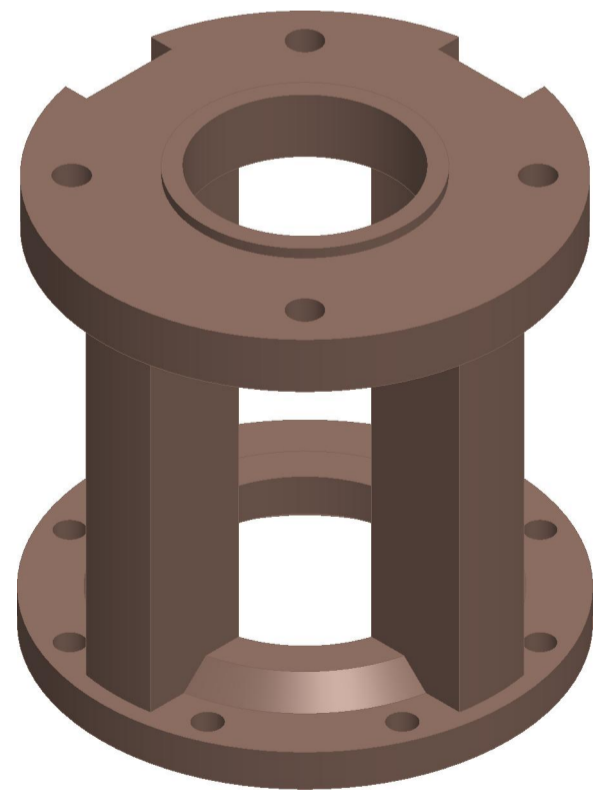

MICROCARE TECHNIQUES P. LTD.			
42/43, Manorath Industrial Estate, Nr. Milan Talkies, Saraspur, Ahmedabad - 380 018, Gujarat, INDIA. e mail: microcare25@hotmail.com			
PART NAME:		IP 293	
MATERIAL:		DESCRIPTION:	
CAST IRON		WEIGHT:- 1.1 Kgs	
		SCALE 1:2	
		DATE 18-11-2011	