

8 BLADES
EQ. SP.
(A.C.W.)

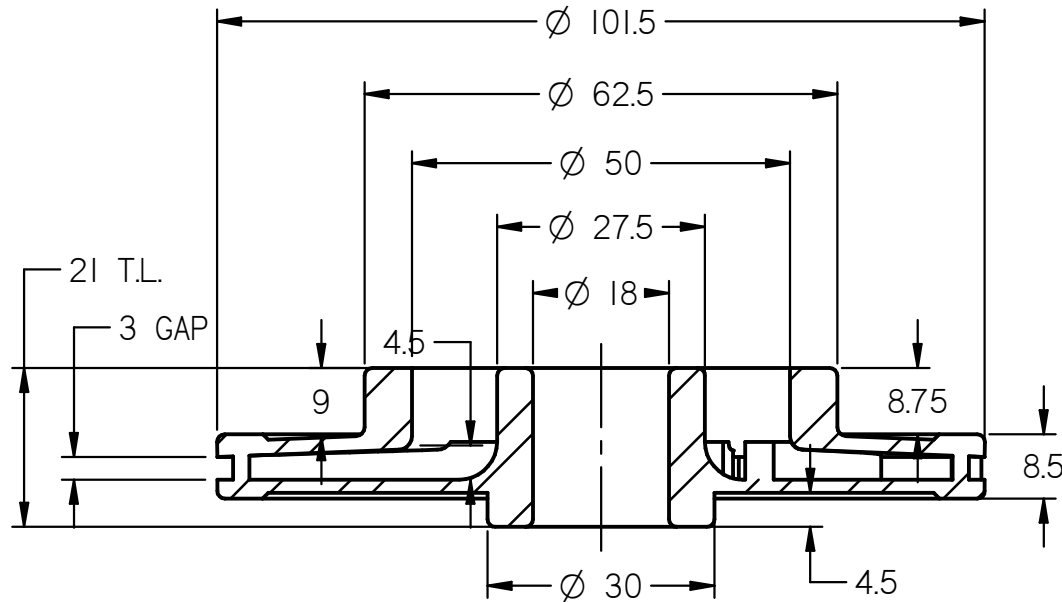
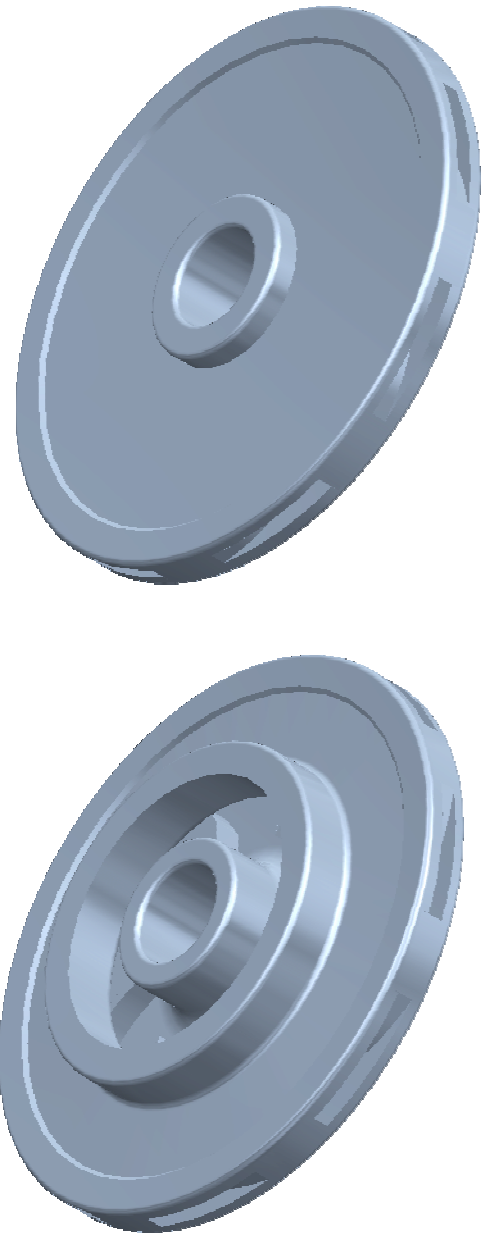

NOTE : ALL DIMENSIONS ARE IN mm.

DO NOT SCALE, IF ANY DOUBT PLEASE ASK.

ALL DIMENSIONS ARE AS CAST

SECTION A-A

Material : S.S. 410	Head : Duty Point / Shut Off : 8 / 12 Mtrs.	MS 30 RF IMPELLER
Weight : 400 kg	Power : 0.30 H.P. / 0.22 K.W.	
Borewell : 6"	Flow : 6 M3 / Hr , 100 L.P.M.	TAPER GAP 4.5 TO 3 mm
Scale : N.T.S.	Nos. of Blades : 8 ACW	
Date : 10 . 01 . 2012	Motor R.P.M. : 2880	Shell Mould

KEY WAY
6 X 1.8

MODEL DRG. NO : MS-153-M

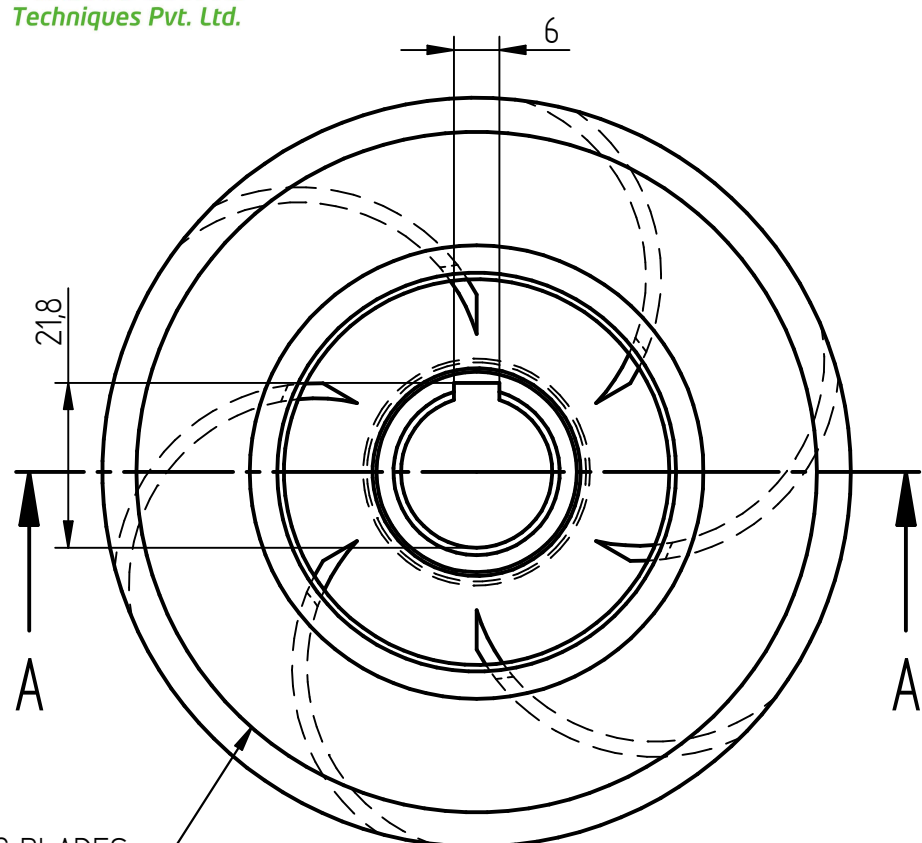
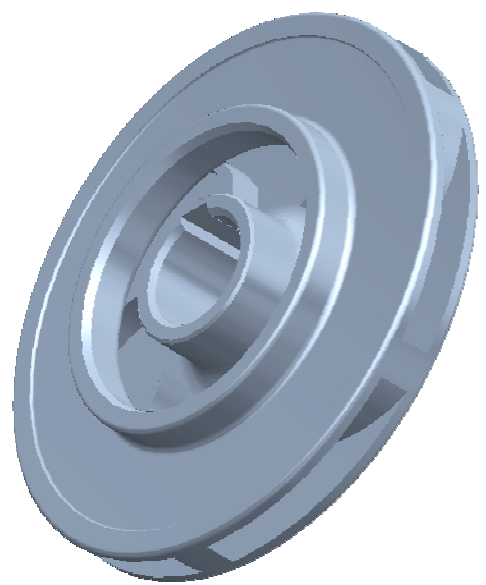

6 BLADES
EQ. SP.
(A.C.W.)

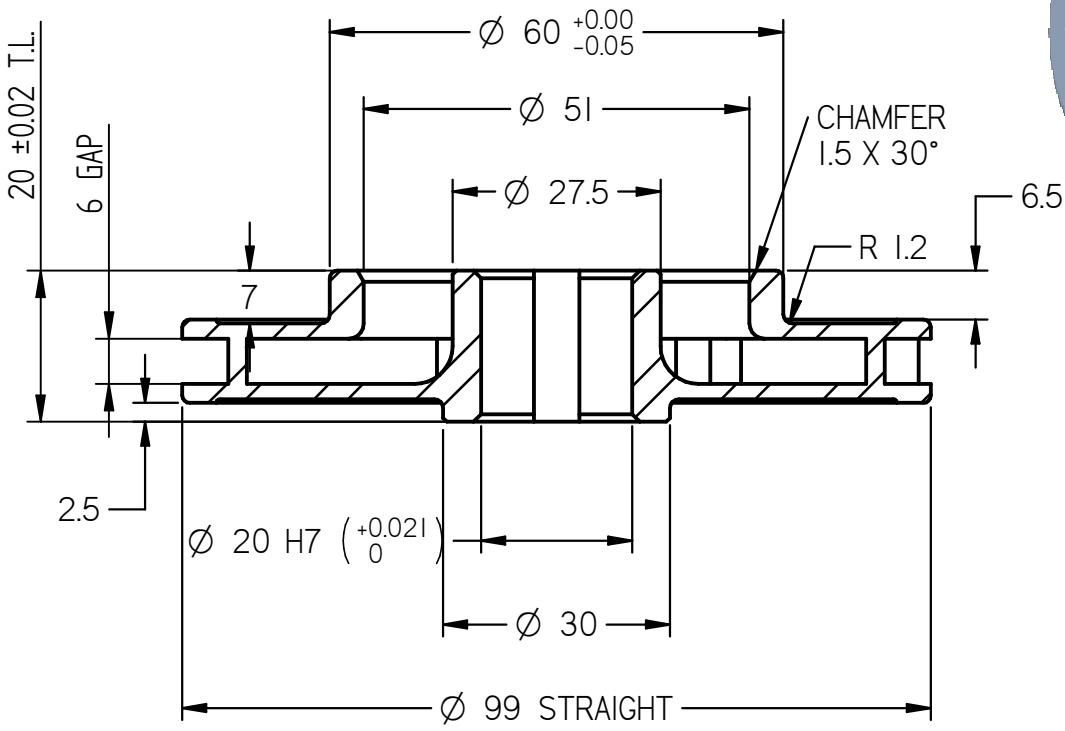

SECTION A-A

NOTE : ALL DIMENSIONS ARE IN mm.
DO NOT SCALE, IF ANY DOUBT PLEASE ASK.
ALL DIMENSIONS ARE MACHININED

Material : S.S. 410	Head : Duty Point / Shut Off : 8 / 12 Mtrs.	MS 40 RF IMPELLER
Weight : 0.375 kg.	Power : 0.4 H.P. / 0.3 K.W.	
Borewell : 6"	Flow : 9.6 M3 / Hr , 160 L.P.M.	GAP 6 mm
Scale : N.T.S.	Nos. of Blades : 6 ACW	Shell Mould
Date : 10 . 01 . 2012	Motor R.P.M. : 2880	