

# DETAILED BROCHURE - MM150C19

## Technical Parameters

Model No	MM150C19
Type of flow	Mixed flow
Borewell Size	8"
Flow Rate	150 m <sup>3</sup> /hr ( 2500 LPM)
Head / Stage	19 Mtrs
Shut off Head	29.2 Mtrs
Power driven by pump / stage	9.0 KW (12.06 HP )
Pump Efficiency (%)	86 %
Rated RPM	2880 @ 50 Hz
No. of Blades	6 (CCW)
Production Method	Investment Casting
Compatible Bowl Model No.	MMB150C19

Pump Efficiency @ different Head				
	Head (Mtrs)	Flow Rate		Pump Efficiency (%)
		(m <sup>3</sup> /hr)	LPM	
<b>1</b>	19 (Duty Point)	150	2500	86
<b>2</b>	17.10 (-10%)	163.2	2720	80
<b>3</b>	23.75 (+25%)	105.8	1763	75

## Conceptual Design of Impeller

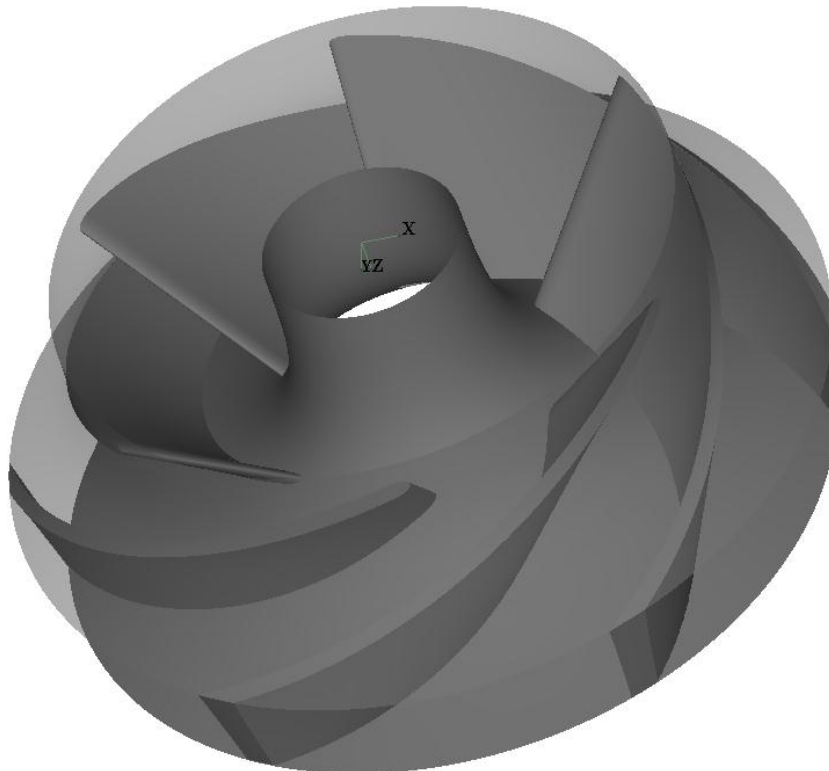

## PERFORMANCE GRAPHS

### 1. Volume Flow vs. Head

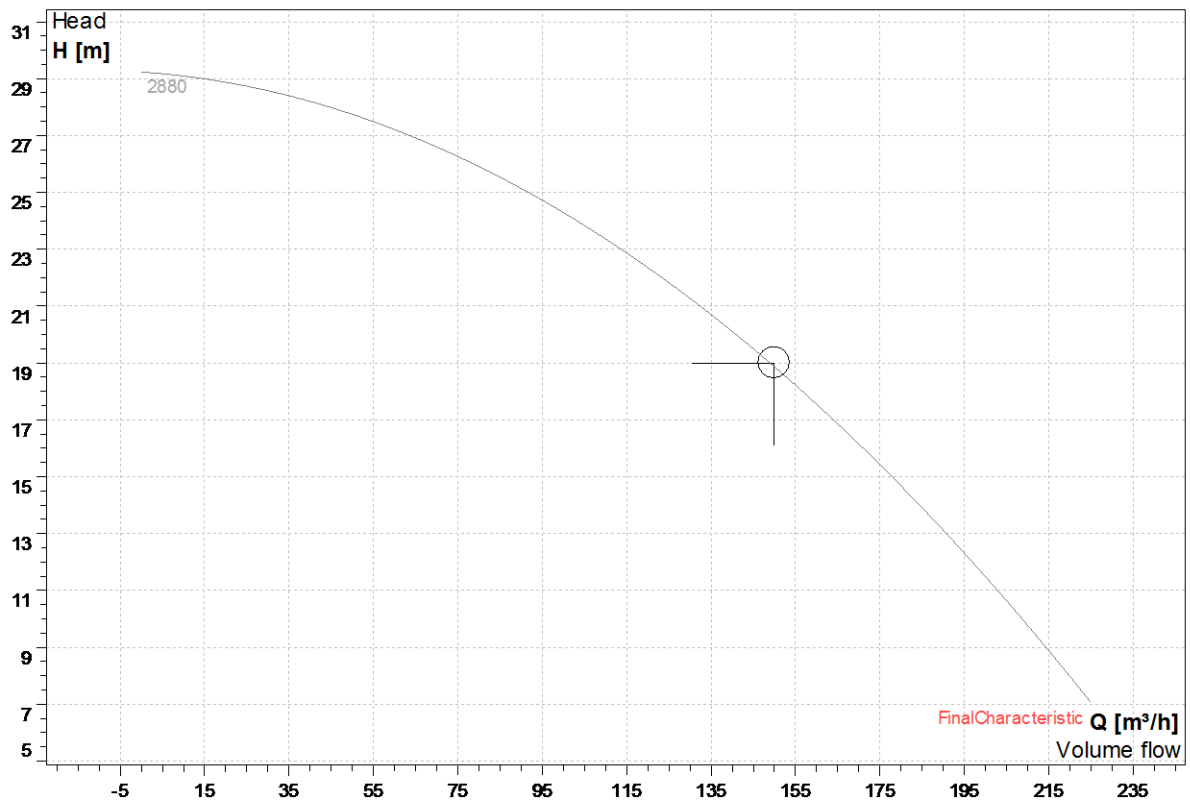

### 2. Volume Flow vs. Total Efficiency

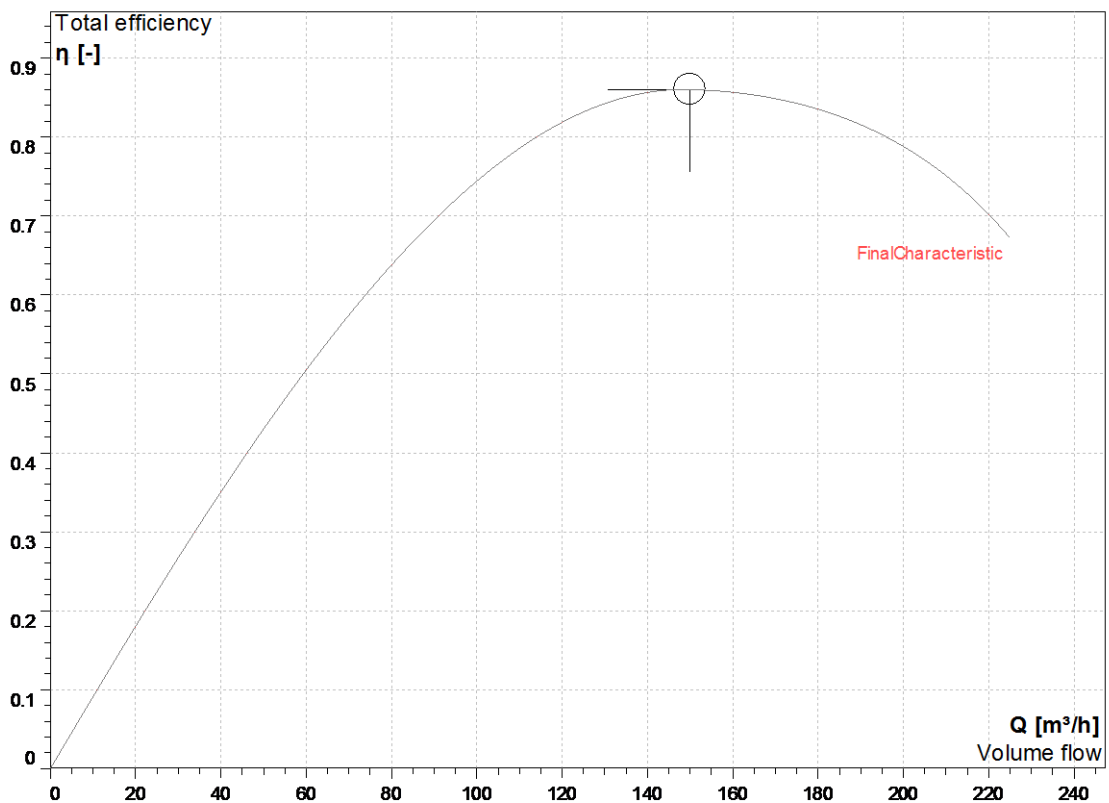

### 3. Volume Flow vs. Required Driving Power

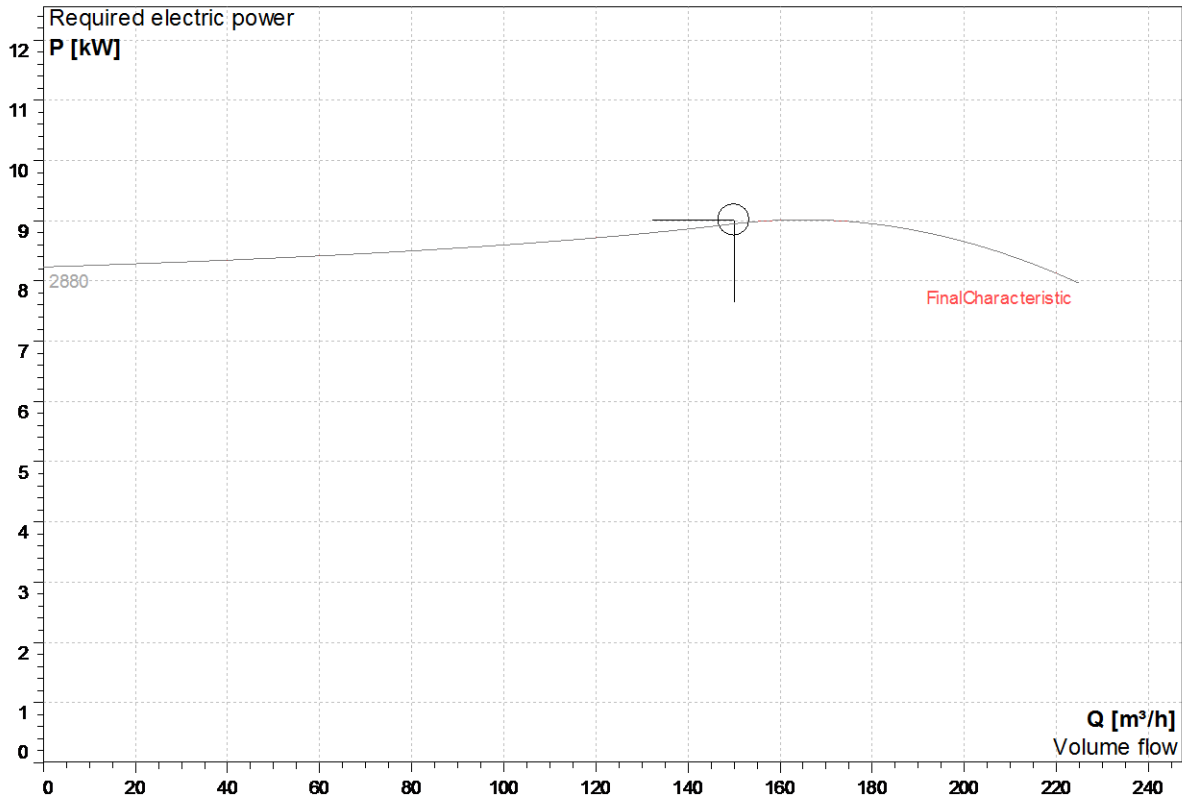

### OVERALL DIMENSIONS (Not to Scale)

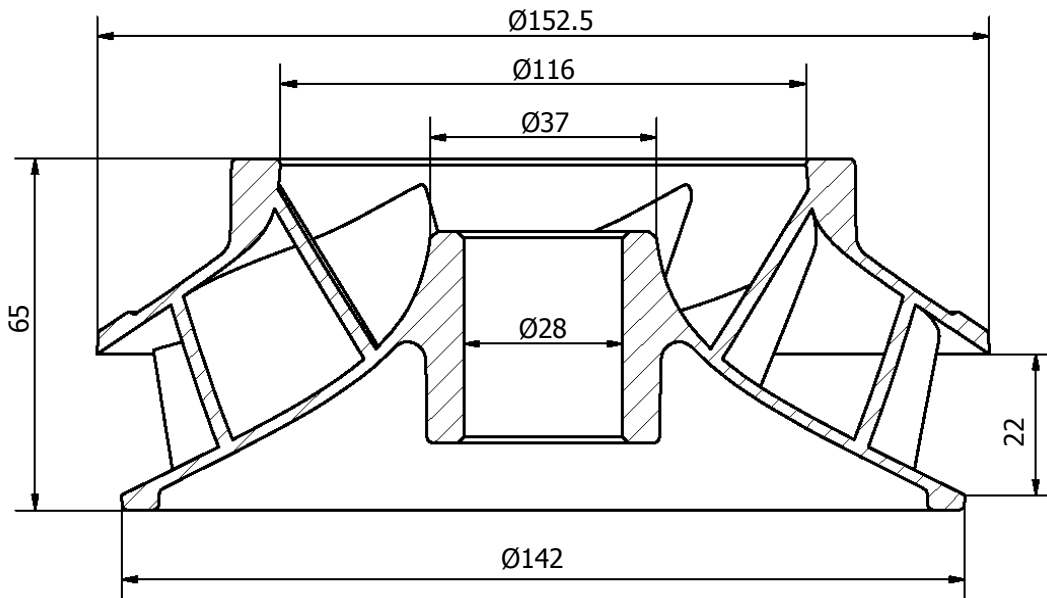

**Note:** All Dimensions are in mm.

For Your query related to this product please write us on [microcare25@microcaregroup.com](mailto:microcare25@microcaregroup.com)

Or fill up the Inquiry form given on our website. [Click here to open Inquiry page](#)