

6 BLADES
EQ. SP.

2 X 45°
CHAMF

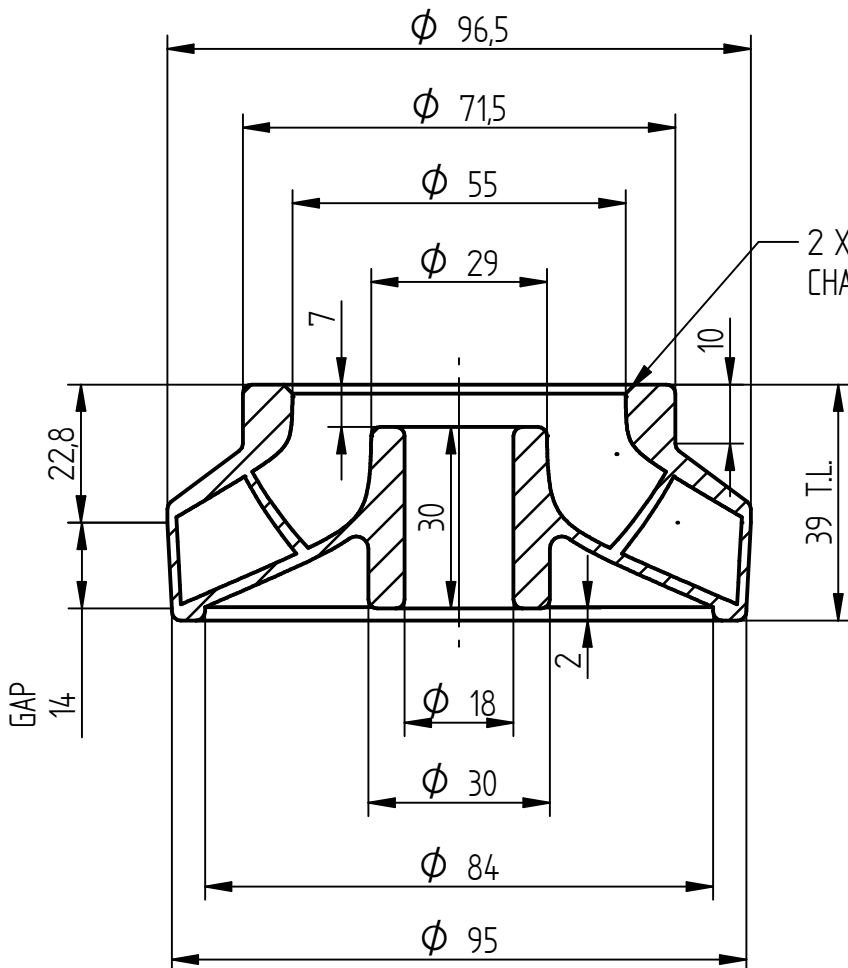

SECTION A-A

**NOTE : ALL DIMENSIONS ARE IN mm.
DO NOT SCALE, IF ANY DOUBT PLEASE ASK.
ALL DIMENSIONS ARE AS CAST**

Material : S.S. 410	Head Duty Point/shut off : 7/11 Mtrs.	M 262 - A IMPELLER
Weight : 0.500 kg	Power : 1.25 H.P.	
Borewell : 6"	Flow : 400 L.P.M.	MIX FLOW - AS CAST
Scale : N.T.S.	Nos. of Blades : 6 ACW	INVESTMENT CASTING
Date : 15.05.2012	Motor R.P.M. : 2880 @ 50 Hz	