

E

D

B

A

Associated Model File Name : NRV\_V4\_1INCH\_THREAD

4

5

Drawing File Name : NRV\_V4\_1INCH\_THREAD

2

1

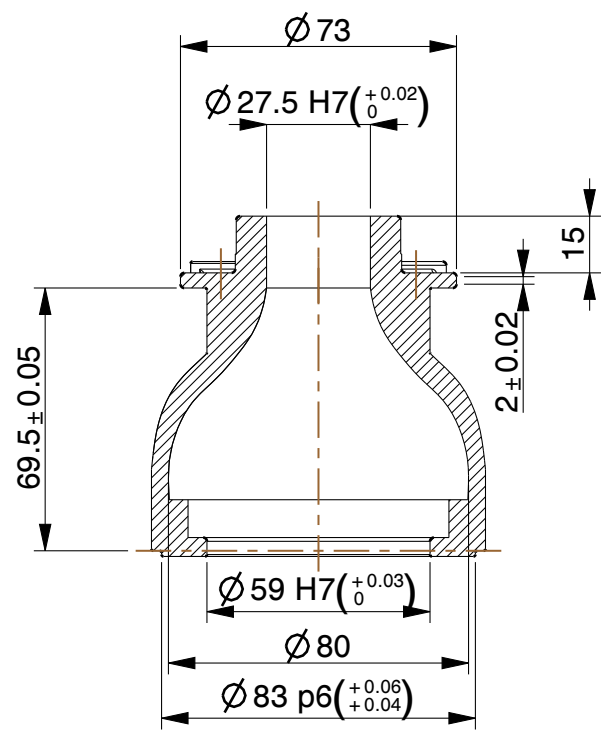
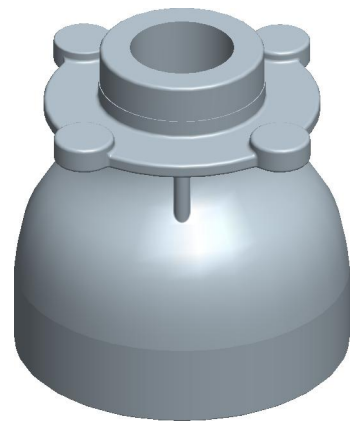
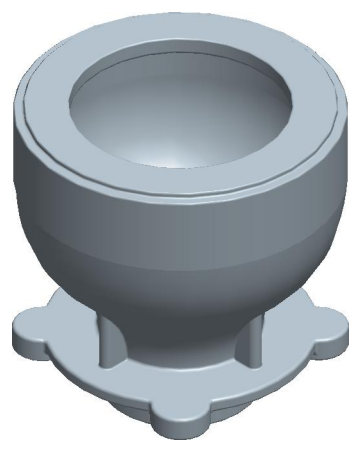
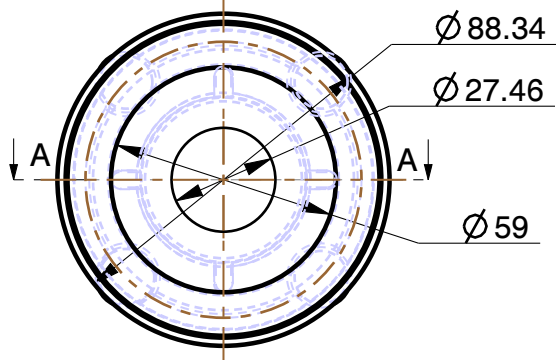

SECTION A-A

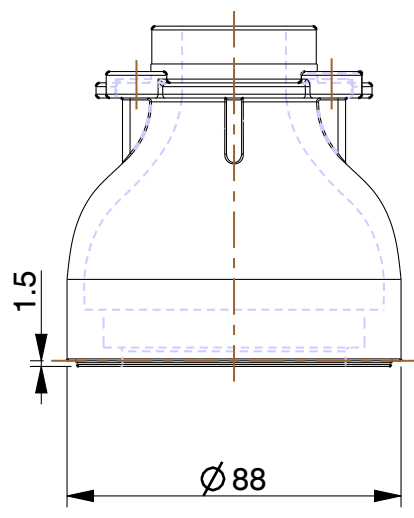

NOTE:-

- 1). ALL DIMENSIONS ARE IN mm.
- 2). DO NOT SCALE,IF ANY DOUBT PLEASE ASK.
- 3). ALL DIMENSIONS ARE AS CAST.(Machined in bracket)

<b>MICROCARE TECHNIQUES P. LTD.</b>		
<i>Survey No.11,Nr. Kalpataru Society, Village : Zundal.</i>		
<i>Dist. :Gandhinagar-382421, Gujarat, INDIA. email: microcare25@microcaregroup.com</i>		
<b>PART NAME:</b>		
<b>NRV_V4_1INCH_THREAD</b>		<b>SCALE</b> 1 / 2
<b>MATERIAL:</b> SS 304	<b>DESCRIPTION:</b> Weight:--- 1.000 Kgs.	<b>DATE</b> 18-11-2011

5

4

2

1