

8 BLADES
EQ. SP.

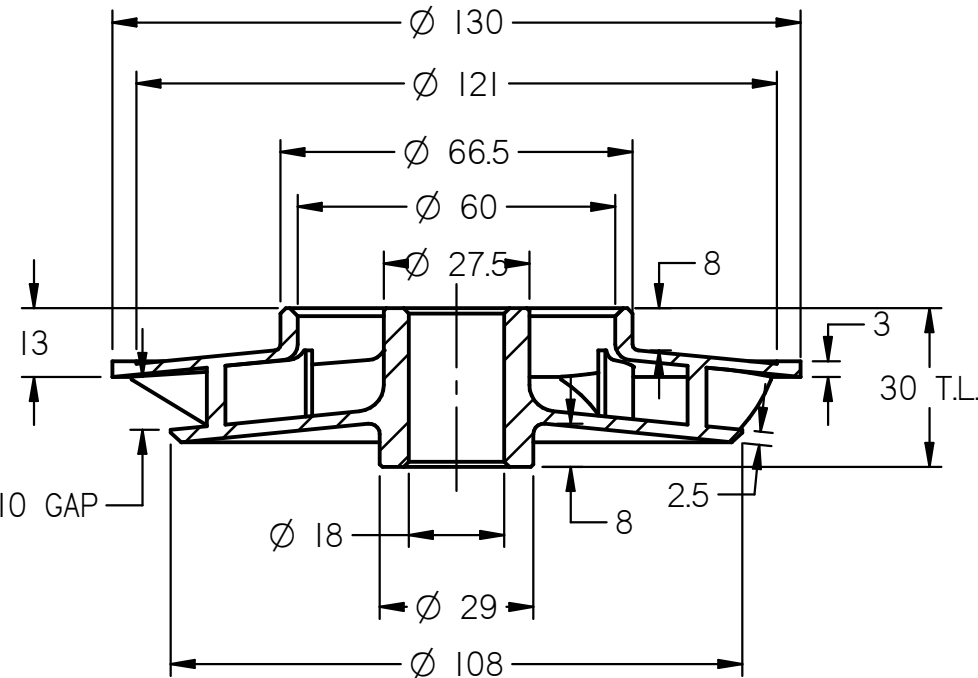
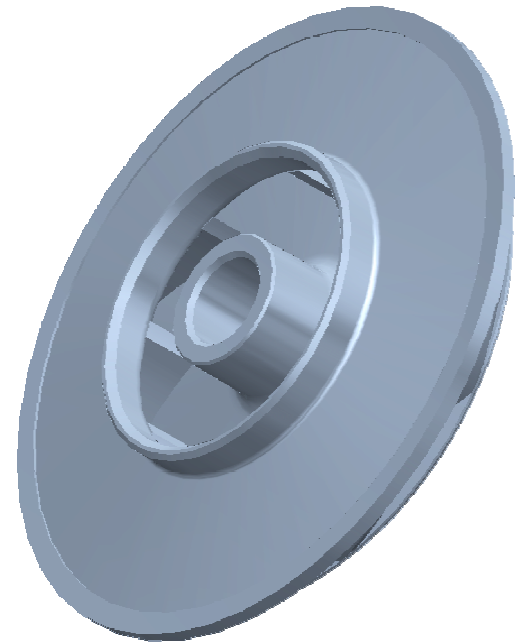
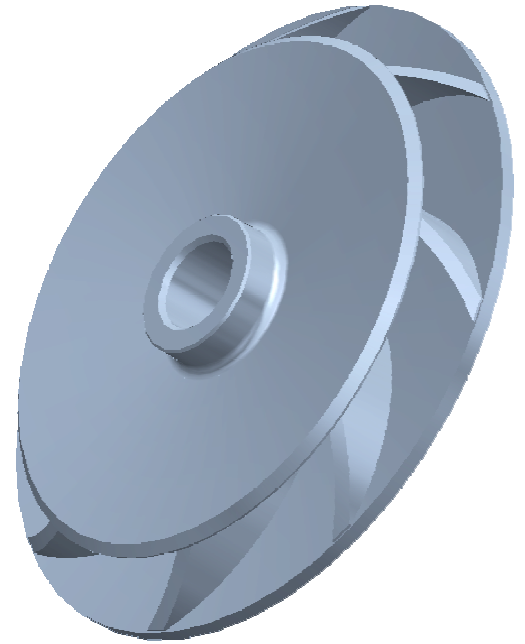

SECTION A-A

**NOTE : ALL DIMENSIONS ARE IN mm.
DO NOT SCALE, IF ANY DOUBT PLEASE ASK.
ALL DIMENSIONS ARE AS CAST**

Material : S.S. 410 / 304	Head : Duty Point / Shut Off : 12 / 15 Mtrs.	M 150 - IMPELLER HH
Weight : 0.525 kg	Power : 1.50 H.P. / 1.12 K.W.	
Borewell : 6"	Flow : 20 M ³ / Hr , 335 L.P.M.	HIGH HEAD 50 FEET
Scale : N.T.S.	Nos. of Blades : 8 A.C.W.	GAP 10 mm
Date : 18 . 01 . 2012	Motor R.P.M. : 2880	INVESTMENT CASTING