

4 3 2 1

H

G

F

E

D

C

B

A

4 3 2 1

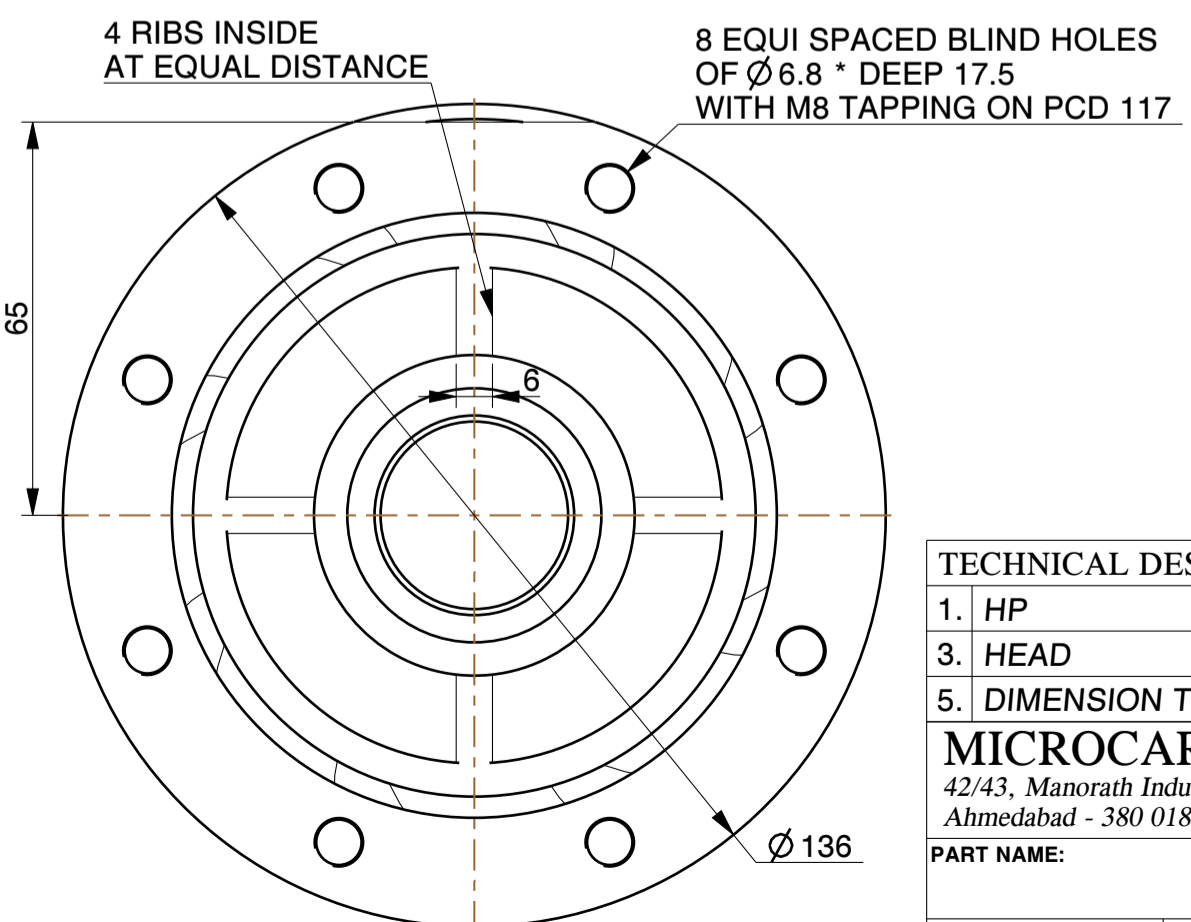
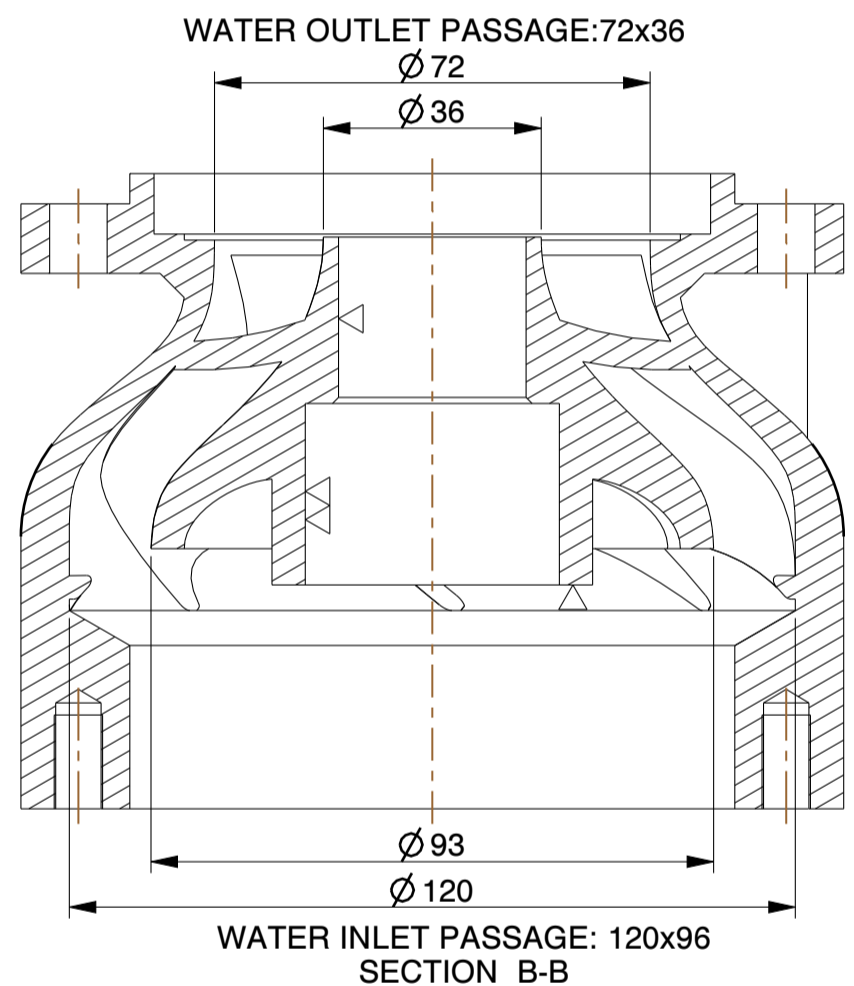
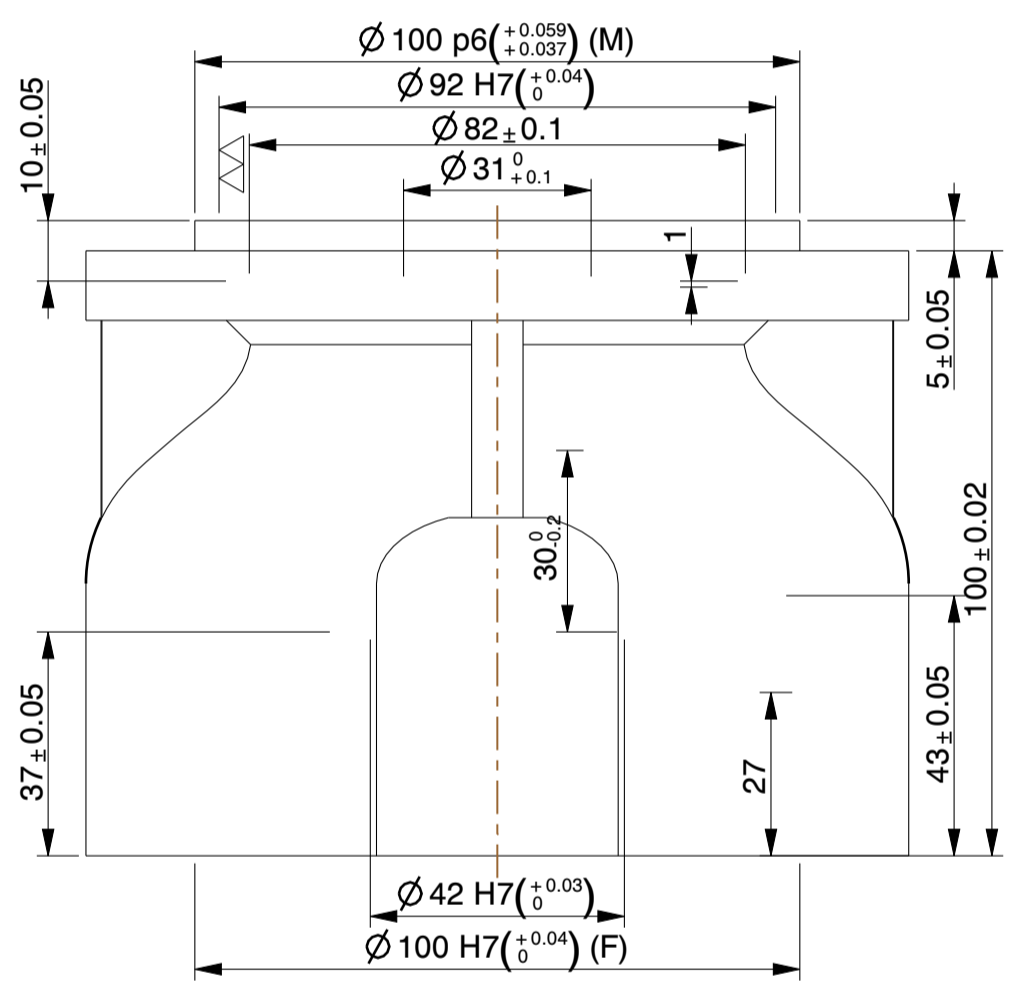
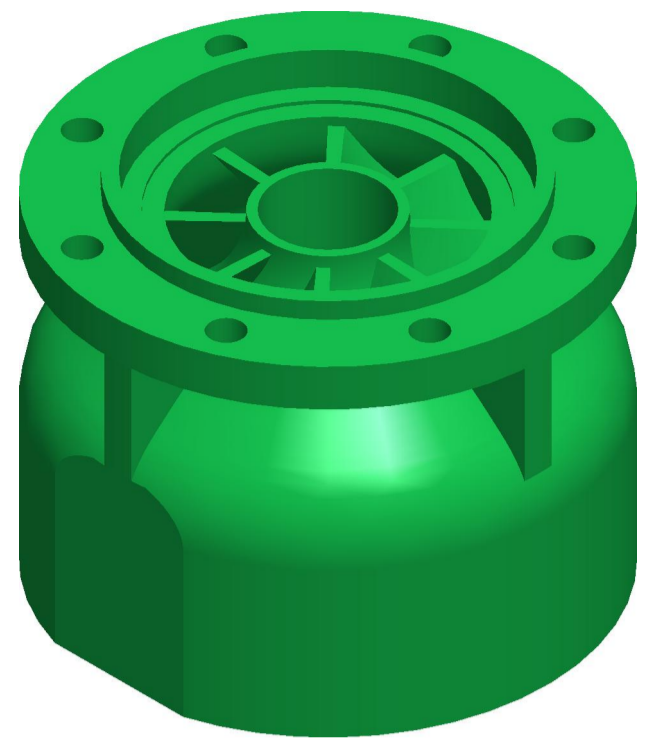
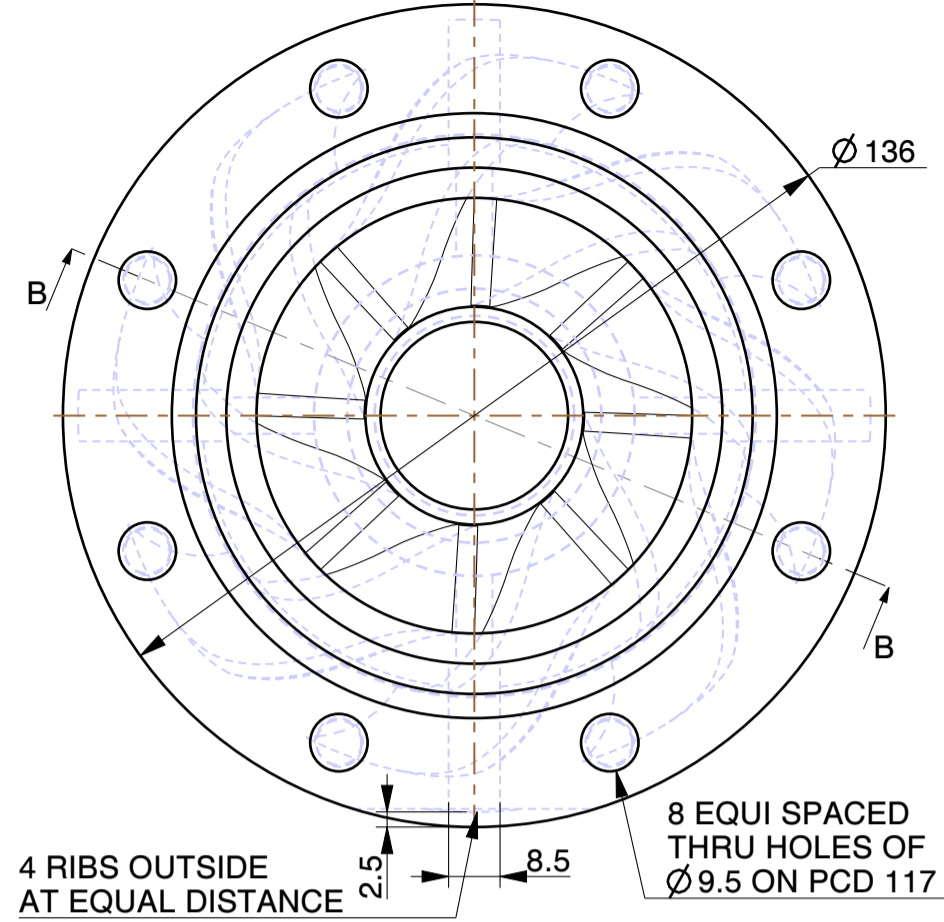

WATER INLET PASSAGE:	120 x 93
WATER OUTLET PASSAGE:	72 x 36

TECHNICAL DESCRIPTION			
1. HP	1.75	2. LPM	600
3. HEAD	7 MTRS	4. NOS. OF BLADES	8
5. DIMENSION TYPE:		AS MACHINED	
MICROCARE TECHNIQUES P. LTD.			
42/43, Manorath Industrial Estate, Nr. Milan Talkies, Saraspur, Ahmedabad - 380 018, Gujarat, INDIA. e mail: microcare25@hotmail.com			
PART NAME:		BOWL - 273	
MATERIAL:		DESCRIPTION:	
CAST IRON		WEIGHT (AS CAST) 5.0 KG	
		SCALE	DATE
		1:1.25	18-11-2011