

4 3 2 1

H  
G  
F  
E  
D  
C  
B  
A

H  
G  
F  
E  
D  
C  
B  
A

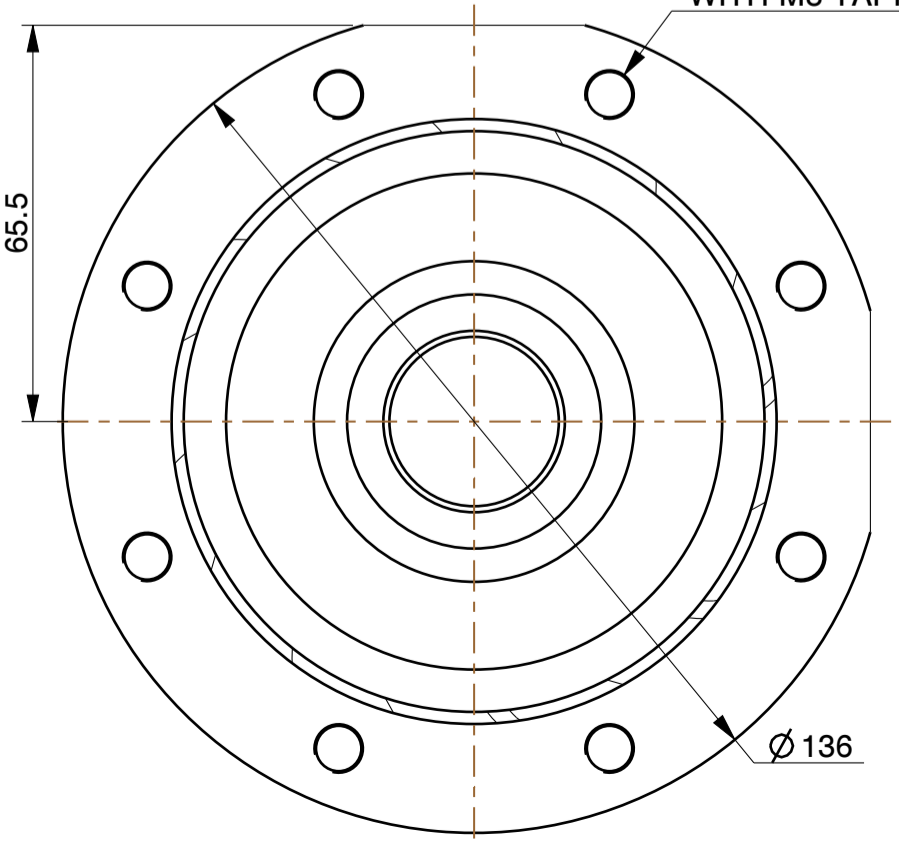
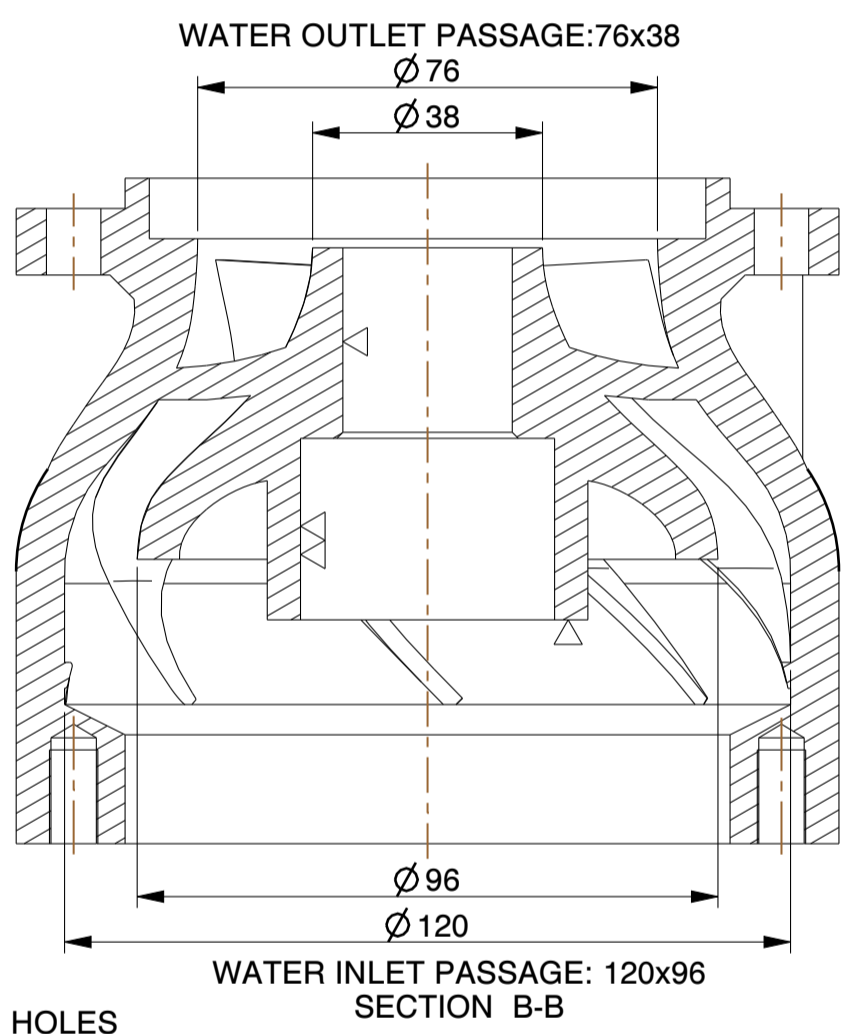
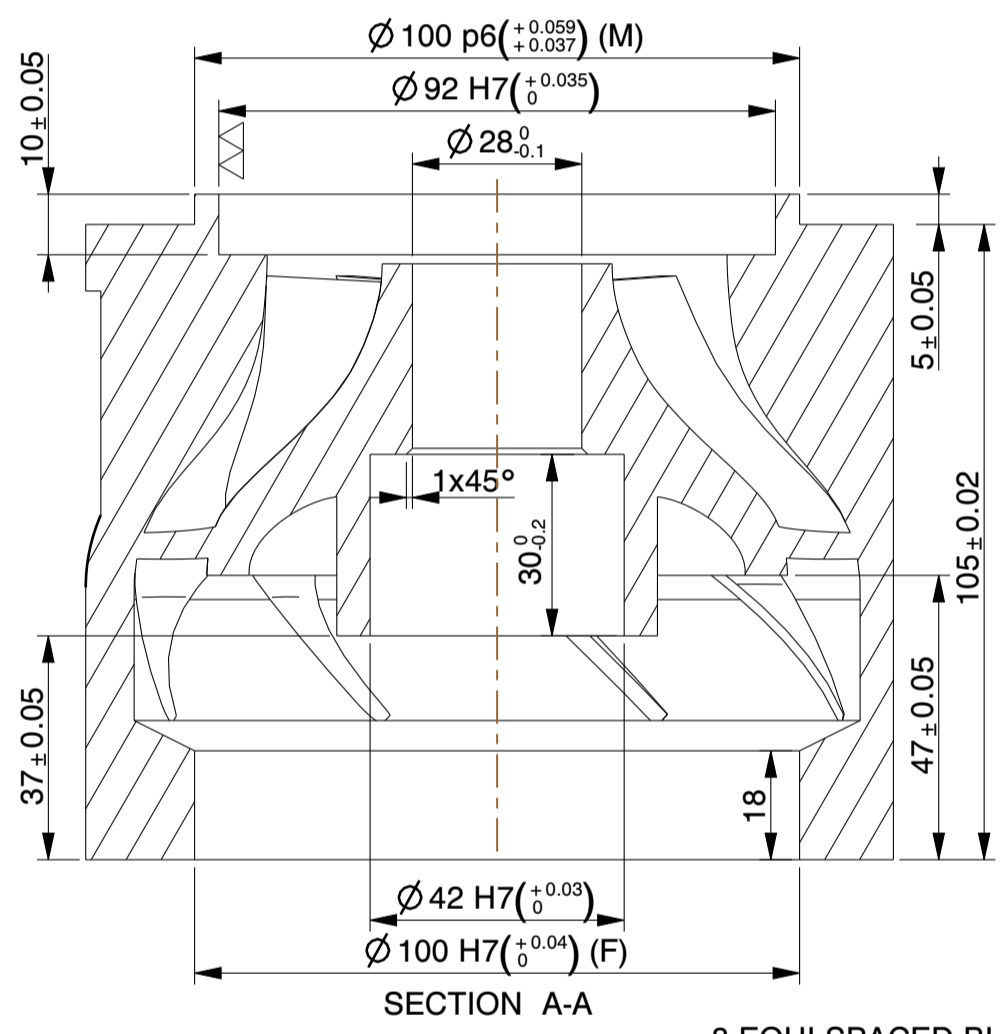
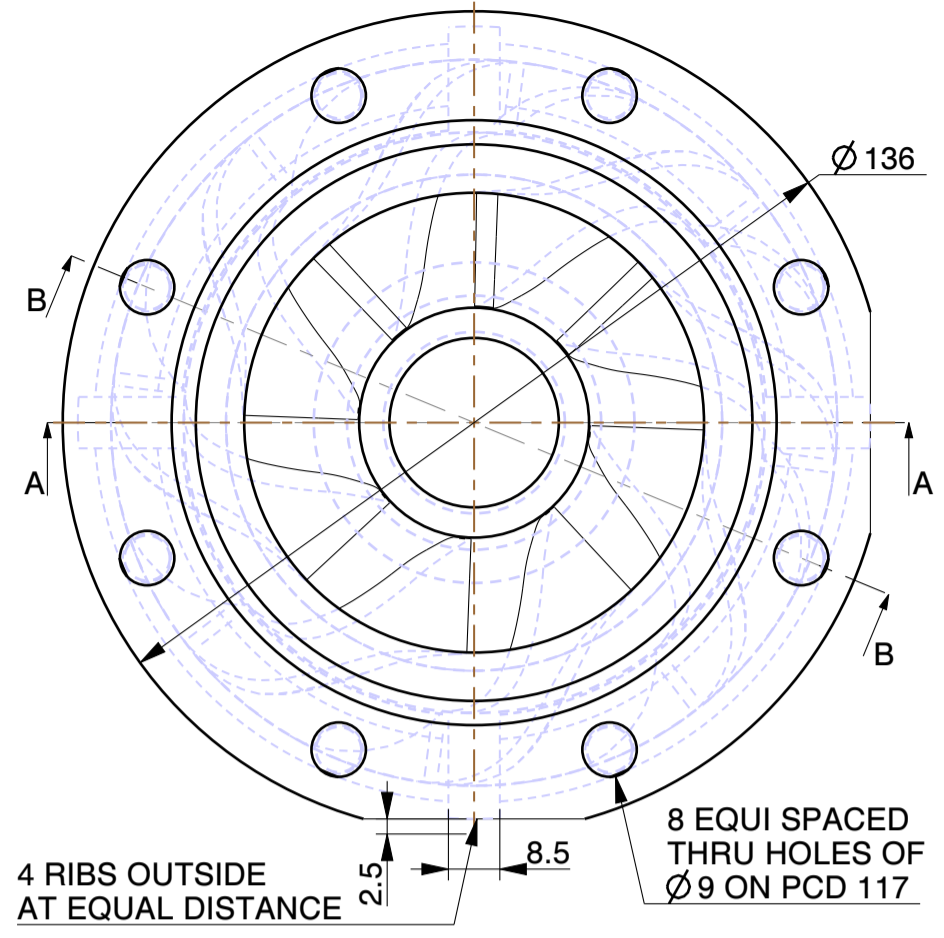

WATER INLET PASSAGE:	120 x 96
WATER OUTLET PASSAGE:	76 x 38

TECHNICAL DESCRIPTION			
1. HP	2	2. LPM	800
3. HEAD	7 MTRS	4. NOS. OF BLADES	8 NOS.
5. DIMENSION TYPE:		AS MACHINED	
<b>MICROCARE TECHNIQUES P. LTD.</b>			
42/43, Manorath Industrial Estate, Nr. Milan Talkies, Saraspur, Ahmedabad - 380 018, Gujarat, INDIA. e mail: microcare25@hotmail.com			
PART NAME:		SCALE	
BOWL - 302 (8 BLADES)		1:1.25	
MATERIAL:	DESCRIPTION:	DATE	
CAST IRON	WEIGHT (AS CAST) 5.0 KG	18-11-2011	